Experimental Researches on Vegetable Assimilation and Respiration. No. I. On a New Method for Investigating the Carbonic Acid Exchanges of Plants

F. Frost Blackman

Phil. Trans. R. Soc. Lond. B 1895 **186**, 485-502
doi: 10.1098/rstb.1895.0010

Email alerting service

Receive free email alerts when new articles cite this article - sign up in the box at the top right-hand corner of the article or click [here](#)

To subscribe to *Phil. Trans. R. Soc. Lond. B* go to: <http://rstb.royalsocietypublishing.org/subscriptions>

X. *Experimental Researches on Vegetable Assimilation and Respiration.*—No. I. *On a New Method for Investigating the Carbonic Acid Exchanges of Plants.*

By F. FROST BLACKMAN, *B.Sc., B.A., St. John's College, Senior Demonstrator of Botany in the University of Cambridge.*

Communicated by F. DARWIN, F.R.S.

Received November 15,—Read December 6, 1894.

Introduction.

FOR the methods employed up to the present for the determination of CO_2 in its physiological relations, Botany is indebted to all three classes of chemical analysis, to volumetric, gravimetric, and gasometric analysis.

To the last belong those methods which have been of great value in giving the relation of O_2 and CO_2 exchange within a given time in either respiration or assimilation. These were the earliest used, and consist in placing a plant or part of a plant within a closed receiver containing a suitable mixture of gases and determining the exact composition of this before and after the experiment. From the reduced volumes, measured after absorption of the CO_2 by potash, and of the O by phosphorus, the quantities of either gas liberated or destroyed can be calculated. To DE SAUSSURE, BOUSSINGAULT, GODLEWSKI, and, above all, PFEFFER, we owe researches based on this method. The method has yielded valuable results in past times, but the corrections and actual analysis, according to the old standard methods of BUNSEN, are lengthy and laborious, while in the modern procedure, simplification of operation is obtained somewhat at the expense of accuracy. The whole method is open to the physiological objections to the use of a closed chamber, and to the continuous, and in a lengthy experiment often considerable, variations of composition which the contained gas must undergo. Nor is it adapted to yield a series of connected results.

Early attempts to determine CO_2 by weighing as carbonate of an alkaline earth (GARREAU, 'Ann. Sci. Nat.,' 3 Ser., 13, 1850), met with but small success, but from gravimetric analysis botanists have successfully borrowed the use of the well known LIEBIG'S potash bulbs. With this method also the actual experiment is usually conducted in a closed receiver, containing, at the commencement, air of known CO_2

17.6.95

content. At the end of the experiment the whole of the contained air is drawn through the potash bulbs with a current of air free from CO_2 , and the increase in weight of the bulbs gives the amount of CO_2 then contained in the receiver. This method, employed by DETMER, KREUSSLER, and DEHERAIN, is simple and convenient but not very delicate, and from the liability of the absorbing potash to lose or gain water, not to be used for experiments of long duration.

The volumetric or method of titration is the one capable of the greatest delicacy in the estimation of CO_2 . The usual procedure is to experiment in a continuous current of air first freed from atmospheric CO_2 , and finally passing through a known volume of standardized solution of baryta, by which the CO_2 that has been taken up from the respiring material is absorbed. At the end of the experiment the solution is decanted and allowed to stand well corked from the atmosphere, until the precipitate of barium carbonate has settled, when a pipette full of the clear liquid is drawn off and titrated against the same amount of the original solution. The loss of strength is a direct measure of the amount of CO_2 absorbed by the baryta. The technique is tedious, and the contamination with the CO_2 of the atmosphere interferes with its accuracy.

There is an extensive field of problems in vegetable physiology, the solution of which involves the determination of small amounts of CO_2 , evolved or absorbed in numerous consecutive short periods, or the accurate comparison of such amounts for small parts of plants placed simultaneously under regulated and contrasted conditions. For the successful prosecution of such enquiries it is necessary that the manipulation involved by the method shall be of the simplest nature, and the time occupied in the determinations the shortest possible. As no method at present in use is sufficient for these requirements, the author has devoted much time to the perfection of one which shall be specially applicable to such questions. The result is an elaborate but compact apparatus, in which carbon dioxide can be both absorbed and estimated, and a current of air can be produced, either free from CO_2 or containing any desired amount of this gas, all without much expenditure of time or trouble, and each process is capable of being carried on continually for any desired time. This conjunction of continuous generation of carbon dioxide with continuous estimation allows problems of assimilation to be attacked equally with those of respiration.

Of the Method.

In this apparatus the estimation of carbon dioxide is performed volumetrically, by passing the current of air containing it through a known volume of standard baryta solution, and afterwards titrating with hydrochloric acid, phenol-phthalein being used as indicator. The procedure is, however, so elaborated that by great complications of apparatus great simplification of technique is obtained. The whole manipulation consists in the turning of taps. The method of estimation is so delicate that

with active organs single experiments may be of but a small fraction of an hour's duration, and may be taken continuously for many hours, while the titration at the end of each is made immediately and occupies only a few minutes. As the *raison d'être* of this apparatus is to be found in the perfection of details and their adaptation so that all the various processes can be performed with the minimum of error, time, and labour, it will be necessary to describe it fully throughout.

The fundamental point at which it departs from the ordinary absorption of respiratory CO_2 by baryta in a PETTENKOFER'S tube, lies in the fact that the titration after absorption is performed in the closed absorbing chamber without bringing the solution into contact with air. Only a small quantity of baryta solution is used in each experiment, and the whole of it is titrated afterwards. This does away with the errors introduced into the usual method by clearing out the tubes, and measuring off a volume of the solution for titration. Again, the burettes containing the standard acid and baryta solutions are both in air-tight direct connection with the absorption chamber; in this way very delicate end reactions can be obtained, as the addition of both solutions can be continued till a satisfactory final colour is obtained, and this is so secured from the action of atmospheric CO_2 that it may remain in the chamber for many hours without change.

Another point of great practical importance in saving time is that the baryta chambers in which the titration is performed require no regular cleaning out. As soon as the titration is complete the liquid within them is of course neutral. It is then quickly let out (see below) and the chamber is immediately ready for a fresh quantity of baryta, the traces of neutral liquid left behind being negligible.

The botanical advantages of the apparatus are, that the necessary parts being in duplicate two different parts of a plant, such as the two surfaces of a leaf for instance, can be examined simultaneously, either as to their respiration or assimilation; further, two practically separate experiments, or even one on respiration and one on assimilation, can be carried on at the same time. The organs examined are always under atmospheric pressure, and in a continually renewed current of air.

The whole apparatus is secured to a slightly raised wooden stand, fig. 1, so that it can be carried safely about entire. Figs. 1–5 are diagrammatic representations of the various parts, which may be considered as grouped into two ranks, one in front, fig. 1, and the other behind, figs. 2, 4, and 5. The aspirators, which are not fixed to the stand, are shown in fig. 3.

In the centre of the apparatus (fig. 1) is a large retort stand, bearing on either side a pair of burettes which open below into two cylindrical chambers in which the absorption of the CO_2 takes place; each of these ends below in a stop-cock and a tube which passes through the stand, and has a free end over a dish into which the waste solutions are passed. At the back of the stand, fig. 2, are two large bottles containing the standard solutions. To the left, in front, is a square vertical board fastened to a second smaller stand, and arranged to support a complexus of tubes and

Fig. 1.

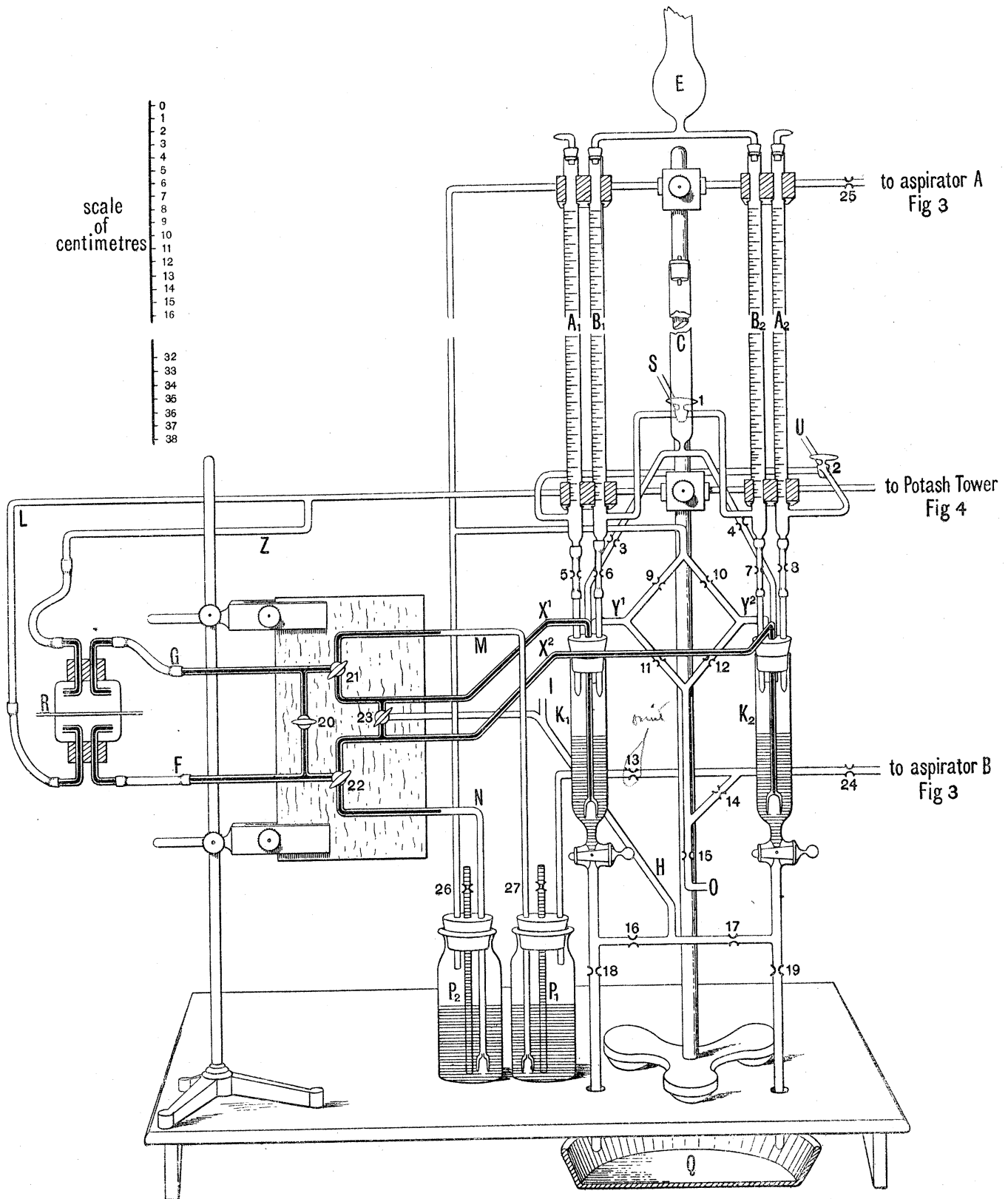

stop-cocks which are essential for the manipulation of the various connections. This will be known as the "switchboard." In the centre behind, fig. 2, may be seen a pair of WOLFF'S bottles and a connecting bulb tube, all containing strong caustic potash, through which a current of air can be forced by finger bellows, Q, the motive power of the apparatus. To the right behind, fig. 4, is a sort of "scrubbing tower," in which a continual stream of strong potash flows from the bottle above to the bottle below over glass beads, while through it air can be drawn and freed from CO_2 to be supplied to the plant under investigation. To the left and behind, fig. 5, is the CO_2 generator. There are to be seen further two small bottles in the centre in front, fig. 1, which will be called the "resistance bottles."

The interaction of these parts is briefly as follows:—By an aspirator, fig. 3, a current of air is produced which passes from the outer air in order through the potash tower to the receiver in which the plant is placed, then through some of the tubes on the switchboard to one or other of the cylindrical baryta absorption chambers, the baryta solution in which absorbs the CO_2 taken up from the plant, and thence to the aspirator. In working on assimilation the air passes through the CO_2 generator and not the potash tower.

We may describe then—

- (1) the absorption chambers ;
- (2) the burettes and standard solution arrangements ;
- (3) the compressed air mechanism ;
- (4) the aspirators ;
- (5) the switchboard ;
- (6) the potash tower ;
- (7) the CO_2 generator ;
- (8) the resistance bottles ; and lastly
- (9) the plant receivers.

Finally, the method of using all the parts together must be explained, with other points in the manipulation.

All the taps and clips are numbered in one series, and are only represented diagrammatically in most of the figures.

I. *The Absorption Chambers* (fig. 1).

These consist of two cylindrical stoppered funnels about 1 inch in diameter, K_1 and K_2 .

Each is closed above by a caoutchouc stopper through which pass five tubes. One of these (X) comes from the switchboard and ends near the bottom of the chamber in a bell-shaped mouth. Through this the air current passes into the chamber and bubbles up through the baryta solution contained in it. Through another (Y) the

air current passes out through one or other of the arms of the diamond-shaped centre piece to one of the two aspirators, A and B. The other three tubes end just within the top of the chamber. They communicate above, through india-rubber tubes fitted with clips, with the burettes containing standard acid, A, baryta, B, and the reservoir of the indicator solution, C. Both chambers are counterparts of one another. They terminate below in stop-cocks carefully ground in, the tube beyond which has a side arm communicating through H with the compressed air supply, I, fig. 1, H, fig. 2, and a straight continuation through the stand, furnished with a clip by means of which the liquid in the baryta chamber can, after titration, be let out into the dish, Q.

The air inlet tube should, as will be explained later, be made of tubing of narrow bore* (1 millim.); but from such a narrow ending bubbles do not break regularly, which leads to imperfect absorption. It was found, however, that the dilated ending entirely did away with this difficulty.

II. *The Burettes and Standard Solutions* (figs. 1 and 2.)

The burettes are of 25 cub. centims. capacity, rather narrow, and graduated into $\frac{1}{10}$ cub. centims. Their connection with the absorption chambers has been mentioned. They are replenished through side tubes, S, U, which communicate with the reserve bottles of standard solution, R, T, fig. 2. The two centrally placed burettes contain the baryta solution, and the two outer ones the HCl. The HCl burettes end above in a fine open tube, bent to exclude dust. The air admitted to the baryta burettes passes through a tube containing soda lime to prevent the entrance of CO₂ (E, fig. 1).

The burettes are supported vertically in pieces of cork cut to receive them, so that their front graduated surfaces are at no place obstructed. The central tube, C, contains an alcoholic solution of phenol-phthalein.

In fig. 2 are shown the bottles of standard solution, each of 2 litres capacity. R, the baryta solution, and T, the acid; the long tube, S, U, within each communicates through three-way stopcocks, 1 and 2, with the burettes. The short tubes just piercing the cork unite and pass to the air pressure arrangement, L, M, N, by which the standard solutions are forced up into the burettes.

The reason for forcing the standard solutions up into the burettes by a pressure of air rather than allowing them to descend from bottles placed high up, which is the usual method, is as follows:—Whenever the burettes are re-filled, the rising liquid forms a very irregular meniscus, of which trustworthy readings cannot be taken. To form a satisfactory meniscus the liquid must be allowed to descend again a little down the wetted surface. In the usual arrangement this is easily done by letting a little of the solution out at the lower end of the burette. This little would in this apparatus pass into the absorption chamber, and have to be neutralized with HCl before another absorption could be commenced. This waste of time and labour is

* By mistake, the narrow bore is represented as a single heavy black line throughout the figure.

obviated by the use of the air pressure. When it is desired to lower the levels of the menisci in the burettes, the pressure of air is reduced, say by opening clips 16 and 18 connecting with the external air, and then on just opening the stop-cocks 1 and 2 a little solution will run back into the stock bottle and a good meniscus at any desired point be obtained.

Fig. 2.

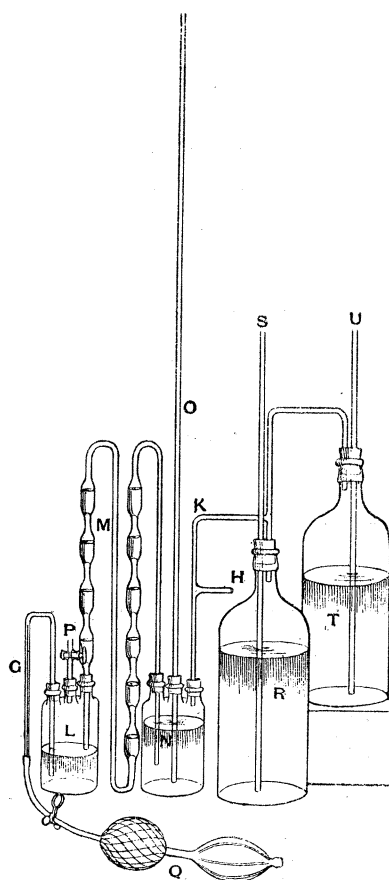

When the stock of standard solutions in the bottles is exhausted, they are refilled through tubes, passing through their corks, which are not represented in the figure.

III. *The Compressed Air Supply* (fig. 2).

Air compressed by the finger bellows Q (fig. 2), and freed from CO_2 by passing through two WOLFF's bottles of strong KHO and the connecting tube M, is used for three purposes, (1) to stir up and mix the liquid in the baryta chamber during titration; (2), to force this liquid out after titration; and (3), to raise up the standard solutions into the burettes, which last process has been already explained.

The finger bellows are compressed several times, and a stream of bubbles, moderated by the capillary tube G to render the absorption more complete, enters the first

bottle L. The connecting tube M has 10 bulbs full of potash in the course of its length, through all of which each bubble of air must pass, as well as through the second bottle N. All these contain 1 in 2 caustic potash, and if the finger bellows be worked as rapidly as the capillary G will allow, this absorption is sufficient to remove all apparent traces of CO_2 from the air stream. The air thus forced in accumulates under pressure in the upper parts of the bottles N, R, and T, ready to fulfil any of its functions. The tube O is open above, and acts as a gauge by which it can be seen if the pressure be suited to the required use.

It is important that all traces of CO_2 should be removed from this air stream, since not only is it used as a stirrer during titration, but it is stored in the bottle containing the standard baryta solution R, the continued clearness of the surface of which liquid shows that the desired end is attained. In course of time much of the potash in the bulbs of the tube M gets carried over by the air stream into N. This can then be returned by working the bellows till the gauge shows a very high pressure, and then opening the stopcock P, when the potash is driven back from N into L, and the tube M completely refilled. For the first and second uses the air pressure is communicated along the branch H, fig. 2, to I, fig. 1, and so either to the switch-board through 23 or along an arm H, fig. 1, connecting with the outlet tubes of the baryta chambers, for stirring purposes. These will be considered further on.

IV. *The Aspirators* (fig. 3).

There are two of these, and they are so constructed that the flow can be easily regulated to any required rate, and that it shall continue constant at this rate without attention. Each consists of a large wide shallow bottle containing about 10 litres, and closed with a well-fitting cork, through which pass four glass tubes for various purposes. The water flows out in drops through a syphon tube W—V. This tube V is held in a special clamp, by which its level can be finely adjusted, and the rate of outflow so regulated. The air current is drawn into the aspirator bottle through a tube X, which opens under the water about three-quarters of the way down the bottle. Consequently the aspirator works on the principle of "MARIOTTE'S bottle," according to which the water flows out at a constant rate so long as the level of the water in the bottle (which must be closed at its mouth) is above the opening of the tube in through which the air is drawn. The rate of outflow is only due to the difference of water-level between the mouth of the inlet tube and the mouth of the outflow tube, *i.e.*, the distance between the dotted lines in the figure. Of the other two tubes that pass through the cork, the central one with the wide stoppered upper end is used for refilling the bottle, while the fourth, Z, is quite short, and gives exit to the air when the bottle is being filled.

The rates of flow that are suitable for the apparatus are very slow, only 40 to 100 cub. centims. per hour, which means about 12 to 30 drops a minute escaping

from the outflow tube of the aspirator. The difference of level required to produce so small a flow is only a few millims., unless some special resistance to the flow is introduced, and without this the simple repeated formation of the bubbles at the inlet tube affects the rate and renders it inconstant. After numerous experiments I have found that drawing out the end of the outflow tube W, which is within the bottle, to a long and not too fine horizontal tube, succeeds excellently as a resistance. The column of water required to produce the desired outflow is now much longer, and the rate can be regulated with the greatest exactness by slightly raising or lowering the outlet tube, the drops being meanwhile timed with a stop-watch. The action of the special fine adjustment for this is almost obvious from the sketch (fig. 3). The outer piece is held in a clamp on a retort stand, by which the coarse adjustment is performed. The middle piece screws up and down in this, and so raises or lowers the outflow tube, which is firmly secured in the uppermost piece (coloured black) which fits loosely into the middle piece, and so is not carried round by its rotation when screwed up or down. The air inlet tubes of the two aspirators connect with the tubes so marked in fig. 1.

Fig. 3.

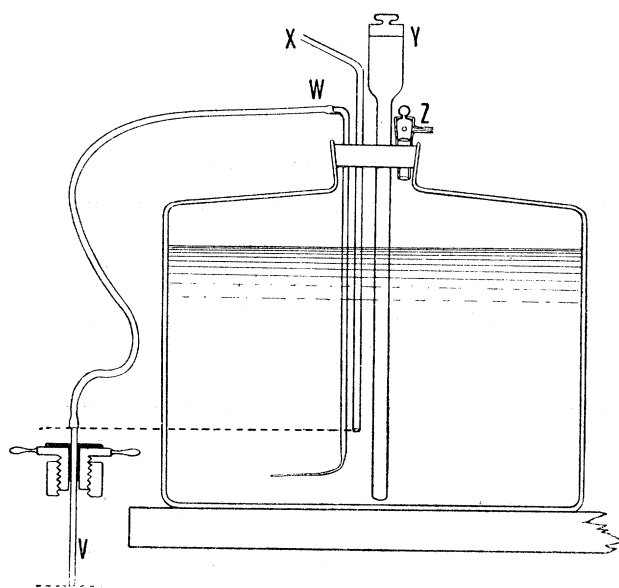

Though the water flows out constantly from the bottle whatever the level of water inside, it must just be mentioned that the air enters at a slightly varying pressure. The first 100 cub. centims. of water flowing from the full bottle sucks in a volume of air which measures 100 cub. centims. at the pressure of the atmosphere minus the whole height of the water column above the dotted line, but the last 100 cub. centims. of water (at level of the line) introduces a volume which is 100 cub. centims. at practically atmospheric pressure. At the quickest rates the level of the water only falls 5 centims. in 24 hours, so that only the negligible difference of 0.5 per cent. can be produced in this time between the volume of water running out and the volume

of air drawn in. During shorter experiments, it suffices therefore to measure the outflowing water. Quick variations of temperature have a prejudicial influence on the steadiness of the outflow. These may be prevented by placing the two aspirators in a tank of water or in a large box full of sawdust, through holes in the top of which the various tubes pass.

V. *The Switchboard* (fig. 1).

This is an arrangement of glass tubes and three-way stop-cocks by which the interaction of the various parts is effected. The various connections can be followed in fig. 1. The two tubes of entry F and G come from the two chambers containing the material under investigation, and are both symmetrically disposed. Thus, by turning stop-cock 21, the current from G may be drawn either through X_1 and the baryta chamber K_1 , or through the resistance bottle P_1 , the significance of which will be mentioned later. In either case the current afterwards passes through the tube marked to aspirator B: the tube F may connect similarly with either K_2 or P_2 , and so on to aspirator A. Through the stop-cock 20, these two systems can be put into communication, and so a current from one receiver may be either divided between the two absorption chambers, or which is more important, a perfectly continuous absorption may be taken of the current by passing it through one absorption chamber for a given time, and then while this result is being estimated, switching it by taps 20 and 22 through the other chamber, and so on alternately. Only one aspirator, B, is needed for this purpose, and the currents from the baryta chambers pass to it through clips 11 and 14 or 12 and 14 alternately. The tube I from the switchboard is connected with the air pressure, and by means of tap 23 a stream of air under pressure may be forced through either X_1 or X_2 into the baryta chambers. By this means if the lower stop cock of a chamber be opened and those about Y be closed, the solution can be forced out, after titration, into the dish Q and replaced by air free from CO_2 .

VI. *The Potash Tower* (fig. 4).

The air enters at the upper side-tube A, passes down the body, which is filled with large hollow glass beads and out through the side-tube B. This connects with a tube L (fig. 1), passing through the lower corks that support the burettes and away towards the left to the plant receiver.

Over the glass beads in the tower a continuous slow stream of strong (1 in 2) caustic potash flows. This passes out of the bottle C through a piece of bent capillary tubing which is of such bore as to reduce the outflow to a few drops per minute. The tube begins in a hood which prevents dust particles settling in the lumen. The glass beads are of such a largeness that no drops of liquid are retained by capillarity to block the interspaces; the potash gradually collects in the lower bottle (D) which fills in about thirty hours. When full, the stop-cock above it is

closed and a finger-bellows connected with the short tube F, by which means the potash can be driven up the connecting tube E to the upper bottle, whence it is ready to flow down again. The special point in this method of removing the CO_2 from the air is the avoidance of any negative pressure within the plant receivers. As it is, the air stream filters through without encountering any resistance, and there is no tendency to suck gases out of the interior of plants experimented on, or to form leaks.

Fig. 4.

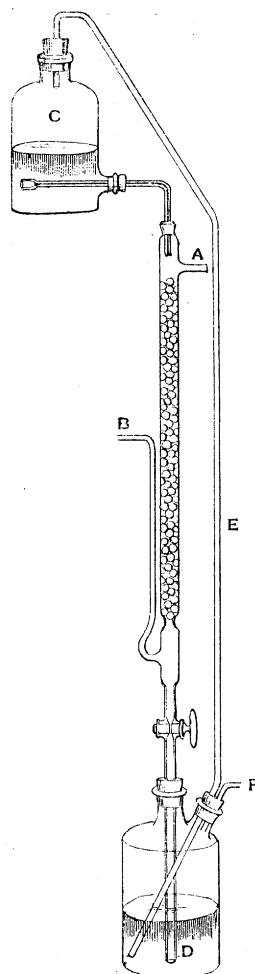

VII. *The Constant CO_2 Generator (fig. 5).*

This consists of an arrangement mechanically very similar to the potash tower but just the reverse in its function. The body of it is a tube filled with fairly large pieces of broken marble (A, fig. 5). Through a capillary tube leading from a constant pressure bottle D, dilute hydrochloric acid drops on to the marble and liberates CO_2 , which is carried away in the aspirated air stream which is drawn in at the open upper end of the tube and passes through B to the receivers. The HCl after passing

over the marble flows away through C, which is so arranged that the liquid keeps a constant level. Very dilute acids $\frac{N}{50}$ to $\frac{N}{1000}$ are alone employed, and by noting the rate at which they drop on to the marble the amount of CO_2 that should be generated in a given time can be determined. If the current of air flowing through be kept constant it will take up a constant percentage of CO_2 in passing through the tube. The tube A is of considerable length, and the arrangement works very successfully if never much more than 1 per cent. CO_2 be introduced into the current of air. The amount that actually is present is determined by passing the current for a certain time through one of the absorption chambers and then estimating the baryta neutralized.

Fig. 5.

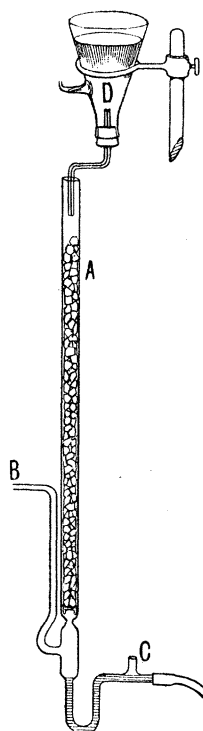

VIII. *The Resistance Bottles* (fig. 1).

These are two bottles, P_1 and P_2 , through which the air stream bubbles when not passing through the absorption chambers. By the centre tubes the amount of liquid in them can be once for all adjusted and the amount of resistance offered to the passage of the air stream thus controlled; their application is given below.

IX. *The Plant Receivers*.

These are of various shapes, but all formed as far as possible on one cardinal principle, that of making the volume as small as possible consistent with the well-

being of the part experimented on. Thus, for entire leaves, chambers are made of two plates of glass of somewhat larger outline than the leaves, and sealed with sealing wax at just sufficient distance from one another round three sides; the leaf and inlet and outlet tubes are introduced through the fourth side and cemented in with wax, the petiole projecting out into water. The capsules employed in working on the two surfaces of leaves are described in detail in a subsequent paper. The smaller the volume of the receivers and capsules employed, the sooner do changes in the CO_2 output or intake by the material make an appreciable effect on the composition of the outgoing gas stream, and the sooner do they become maximal, so that smallness becomes of great importance, and for this same reason all the glass and india-rubber tubing intervening between the receivers and the baryta chambers is of small (1 millim.) bore. In fig. 1 there is shown diagrammatically a pair of receivers adapted to the opposite surfaces of a leaf R for a comparison of the amount of CO_2 given off from the surfaces.

Having now described all the parts of the apparatus, something must be said on the various methods of working them together.

The aspirators are filled with distilled water containing a little mercuric chloride to prevent fungoid growths. As this gradually drops out it is collected in a flask and measured at the end of each experiment. When the aspirator is nearly emptied to the level of the air inlet tube, this water is returned to the aspirator through Y (fig. 3), after closing clip 24 or 25 (fig. 1) and opening Z. Afterwards Y is closed and gentle suction applied to the side-tube at Z, till on clip 24 or 25 being opened bubbles are drawn through the inlet tube X. Z is now closed, and the aspirator is working away as before. The refilling has at the most to be done once in three days and occupies only a minute or two.

When it is desired to absorb the CO_2 of the air current coming from the plant receiver, the current is led through one of the baryta chambers at a rate not exceeding 4 to 6 bubbles a minute. Aspirator B can be put in connection with chamber K_1 through clips 14 and 11, or with chamber K_2 through clips 14 and 12; similarly aspirator A with K_1 through 9, or with K_2 through 10. Either aspirator can thus be employed on either chamber. This allows a titration to be performed in the one chamber without interfering with the current through the other one. While a titration is being made in a given chamber the current is led through the corresponding resistance bottle. Bottle P_1 connects with aspirator B and with the inlet tube G of the switchboard: bottle P_2 with A and the inlet tube F. If a simple connecting tube were used instead of these bottles then, as soon as the current had been switched out of the baryta chamber, it would suddenly go faster, lacking the resistance of the column of liquid in that chamber. When switched back through the chamber it would stop for some time till the aspirator had

got up sufficient negative pressure to overcome this resistance, and even then it would not go as fast as in the interval between the absorptions. This fatal irregularity the bottles overcome by providing a resistance to the passage of the current which is exactly equal to that in the baryta chamber. If this be accomplished, then the current continues to flow with perfect regularity whether it be passing through the absorption chamber or the resistance bottle. In later experiments paraffin oil is employed in the bottles so that the resistance may not alter by evaporation. The equality of resistance is adjusted as follows: P_2 and P_1 are both for the time connected to one aspirator (B) by opening the clips 24, 13, 14, 12, 10, and directing 21 and 22 on the switchboard, so as to let both the air currents pass to the bottles. Bubbles will, of course, only pass through the bottle which happens to offer the less resistance. The amounts of liquid must then be altered through clips 26 or 27 until both columns are exactly equal and bubbles pass equally through both.

Afterwards, the absorption chamber K_1 is similarly equalized with P_1 , and K_2 with P_2 . The amount of liquid required to be introduced into each chamber from its burette to produce this equality of resistance is noted, and becomes the amount of baryta to be afterwards constantly introduced at the beginning of each experiment. For assimilation experiments with the CO_2 generator the constancy of flow obtained by this means is very essential. If, however, slightly too much or too little liquid be introduced into a chamber, and it be consequently noticed that the aspirators drop slightly slower or faster than when the current was passing through the resistance bottles, this can be remedied by immediately lowering or raising the level of the dropping tube of the aspirator by the necessary compensating amount.

In performing the titrations, beyond the addition of the required solutions it is necessary that the whole liquid be stirred up, and that, without introducing any atmospheric CO_2 . A stream of air bubbles supplied both under pressure and freed from CO_2 by the "air pressure" apparatus Q, L, N (fig. 2), is made to serve this end. Suppose that the moment is arriving for terminating the absorption in both chambers and titrating the result. The currents would now be passing (fig. 1) from the plant through F, tap 22, tube X^2 , chamber K^2 , tube Y^2 , clips 12, 14, and 24 (15 opening into the air at O being of course closed), to aspirator B, and from the plant through G, 21, X^1 , K^1 , Y^1 , clips 9 and 25 to aspirator A. At the given moment the taps 21 and 22 are turned so that they lead from the plant only into M and N; the currents shift immediately and pass only through the respective resistance bottles. Clip 13 is not essential, and has been left in by an oversight. Clips 9 and 14 are now shut, and 11 and 15 opened, so that the chambers both communicate with the outer air at O and the titration is commenced. Tap 23 from I, the air pressure supply, can be then turned (it must have, for other reasons, only an L-shaped bore) so that the air passes through either X_1 into K_1 , or through X_2 into K_2 at will, and so out into the air through Y and O. If stirred only in this way a small amount of liquid in the narrow lower part of the chambers would never mix

with the rest. The proper arrangement for stirring is by the connection with the air pressure through H. Open clips 16 and 17, having closed 18 and 19, and then by partly opening the stopcock at the base of the absorption chamber a stream of bubbles forces its way right through the liquid and completely mixes it. This is kept up during titration till the end colour is obtained. This stirring stream of air contains so little CO_2 that it may be bubbled fast through the faintest pink tint in the absorption chamber for ten minutes without decolorising it. The pressure gauge O (fig. 2) affords valuable indication that the air pressure is sufficient to force its way through the liquid, and so avoids the risk of the liquid passing down through the stop-cock instead of the air passing up.

When the titration is finished clips 16 and 17 are closed again, so also 11 and 12. Instead clips 18 and 19 are now opened as well as the two stop-cocks, and on admitting air under pressure through 23 and X_1 and X_2 , the neutral liquid in the absorption chamber streams out through the stop-cocks into the dish Q placed to receive it. The levels of the burettes are now read off; the number of cub. centims. of hydrochloric acid that has been needed to neutralize is multiplied by the factor that relates it to the baryta solution, for the two are never the same strength, and the result subtracted from the volume of baryta solution that has been used. The difference gives the volume of baryta that has been neutralized, other than by the hydrochloric acid, that is to say, by the CO_2 absorbed from the current drawn through the chamber.

In order to prepare for a fresh absorption experiment, a considerable pressure is got up in the air pressure system by working Q, and stop-cocks 1 and 2 are opened. The compressed air in the bottles of standard solutions is thus able to force the respective liquids up the burettes. When the solution is nearly to the top in each, the stop-cocks are shut. Then the air pressure is lowered by opening for a moment clips 17 and 19, which allows an escape of the compressed air. On again opening stop-cocks 1 and 2, the solutions tend to run back to the bottles from the burettes. When the zero mark is reached in each, the stop-cock is finally closed. After this the correct amount of baryta solution is introduced into each absorption chamber by opening the clip of the burette, and also clips 11, 12, 15, to allow the displaced air to leave the chambers. These are all closed again, and just before it is desired to start another double absorption experiment, clips 12, 14, and 9 are opened. At the given moment for starting, there remains then nothing to do but to return the three-ways taps 22 and 21 to their old positions, and the pressure bottles are cut off and the current passes once more, still at the same rate, through the baryta in the absorption chambers.

The whole of this double titration emptying and refilling can be accomplished comfortably in ten to twelve minutes.

At intervals it may be desirable to clean from the chamber the barium carbonate deposited on the walls. This is accomplished without taking the chamber to pieces, by drawing sufficiently strong hydrochloric acid into it through the stop-cock at the bottom,

by gentle suction applied at O through 15 and 11, or 12. When all the barium carbonate is dissolved, the acid is run out below, and the chamber washed and neutralized, when it is ready for fresh work.

We have now to consider the precautions adopted to render the titrations as delicate as possible. Hydrochloric acid is chosen in preference to oxalic acid on account of its greater stability. A dilute alcoholic solution of phenol-phthalein seems to be a very satisfactory indicator. The most delicate shade of pink that can be perceived against a white background (a piece of cotton wool is the best) is taken as the ideal end colour, but unless the amount of CO_2 to be estimated is very minute, a slightly wider range of colour may be considered sufficient. The solutions that I have employed as yet are approximately half decinormal (N/23). This strength of baryta solution unites with just half its volume of CO_2 . The burettes are graduated in $\frac{1}{10}$ cub. centims., and are read by estimation to $\frac{1}{100}$ of a cub. centim. After practice, this is not difficult to do without an appreciable error. To facilitate the reading, I use a very convenient little instrument for avoiding errors of parallax. It consists of a carefully cut, right-angled triangle sheet of cork, along one side of which an opaque glass tube, 9 centims. long, is attached. One end of the tube is just flush with the right angle of the cork, and this end is placed against the burette. A piece of thin paper, with the lower half blackened, is placed behind the meniscus to darken its lower surface, and the level is read by looking through the tube of the instrument. The image is very clear, and the longer and narrower the tube, the less the possible error in reading. The internal diameter of my tube is just over $\frac{1}{10}$ cub. centim. on the burette scale, and after a very little practice the use becomes quite easy.

For such accuracy of reading to be of any avail, the burettes must be quite clean, so that the solutions run down perfectly. Further, in titrating, such amounts of the solutions are always introduced, that by rapid bubbling hanging drops may be just swept off the tips of the burette tubes. In this way half a drop or less can be added to give a final end colour. I now use this method in preference to having the solutions of unequal strengths, which also enables one to practically add small fractions of a drop. The precautions to ensure a good meniscus with the high level reading, which is always taken at one constant point, have been given on p. 578.⁴⁹⁰ The levels of the menisci do not change appreciably by evaporation even after several days. After a little time all these precautions are easily observed, and, then, when the errors of working, which will be dealt with later, do not come in, the error of estimation rarely exceeds $\frac{2}{100}$ cub. centim. of solution ($\frac{1}{100}$ cub. centim. CO_2). Such is the case when successive titrations to compare the relative strengths of the solutions are made; indeed, long series of standardizing titrations may be made with a difference not greater than $\frac{1}{100}$ cub. centim., which is equivalent to less than 0.1 per cent.

In actual experiments slight additional errors come into play. Thus, if a current of air, freed by the potash tower as far as convenient from CO_2 , be drawn through the baryta solution for more than twelve hours, and the solution be then titrated,

a small apparent amount of CO_2 is always obtained. This is usually 0.02 to 0.04 cub. centim. of baryta solution for an all-night experiment in one chamber, and probably due to an actual 0.01 cub. centim. — 0.02 cub. centim. of CO_2 , leaking in, or escaping absorption by the KHO in this long time. I have not thought it worth while, at present, to attempt to eliminate this error of working, which is much less than the amount on which any biological conclusion would be based. If, from absorption of CO_2 , much barium carbonate is present in the solution when the titration is being made, it is not sufficient to be satisfied with the first end reaction that is arrived at. If left, in less than a minute the colour fades away, and more alkali must be added. The real end reaction colour does not change for very many hours when kept closed up.

That the absorption of the CO_2 in the air current is sufficiently well performed by the rather shallow layer of baryta solution employed, is shown in the following experiment, in which a stream of air charged with CO_2 by the CO_2 generator was aspirated first through one chamber and then back to the switchboard by a special tube and through the second chamber. The CO_2 generator added to the passing air stream about 0.2 per cent. CO_2 , and this was drawn for fourteen hours through the two chambers. On titration it was found that 4.08 cub. centims. of baryta had been neutralized in the first chamber, and only 0.06 in the second. This means that at most only $1\frac{1}{2}$ per cent. of the CO_2 had escaped absorption in the first chamber. Actual experiments are never continued so long that so much as 4 cub. centims. of baryta solution are neutralized, so that in ordinary work about 1 per cent. may escape absorption. Since, as a rule, the total baryta neutralized by CO_2 in one experiment does not exceed 1 cub. centim., this error of 1 per cent. becomes .01 cub. centim., which is not greater than the allowed error of estimation, so that but little would be gained by more complete absorption.

To show how far the two chambers furnish comparable simultaneous results, different amounts of ordinary air were aspirated through the two chambers during the same night. In this time one aspirator ran 2040 cub. centims., and the chamber in connection with it showed 0.75 cub. centim. of CO_2 absorbed, which equals 0.037 per cent. CO_2 in the air. The other aspirator ran 1300 cub. centims., and the chamber connected with it showed 0.51 cub. centim. of CO_2 or 0.039 per cent. In another case, 1730 cub. centims. were drawn through one chamber and 1700 through the other. Both gave 0.034 per cent. of CO_2 .

Experiments were also made to determine the accuracy of the CO_2 generator. Approximately $\frac{N}{40}$ HCl was supplied to it and a current of air drawn through it in the usual way. The acid which flowed out of the lower end of the apparatus was collected in a beaker and its strength compared with that of the acid supplied at the top. Of the fresh acid 25 cub. centims. neutralized 12.20 of a baryta solution, while 125 cub. centims. of the acid that had run over the marble neutralized 1 cub. centim.

of this same baryta, *i.e.*, 25 cub. centims. would neutralize 0·2 cub. centim., so that, including the carbonic acid that the liquid must take up on its passage, less than 1·7 per cent. of it escapes undecomposed. The amount of the acid supplied will then furnish a very fair guide to the amount of CO₂ that will be liberated. When the external conditions of temperature, &c., are favourable, a long series of concordant results may be obtained from the CO₂ generator. Thus in one case for five consecutive determinations of the amount of CO₂ generated in periods of 15 minutes by this apparatus, the numbers 0·37 cub. centim., 0·37 cub. centim., 0·37 cub. centim., 0·37 cub. centim., 0·38 cub. centim. CO₂, were obtained.

Results like these necessitate a constancy of external temperature which it is very difficult to obtain. As presently arranged the rate of dropping of the acid in the CO₂ generator varies with the temperature, but I have some expedients, not yet put into practice, by which I feel sure of overcoming this difficulty.

Numerous experiments, showing the capacity of this apparatus for delicate work on both respiration and assimilation, will be given in the succeeding paper "On the Paths of Gaseous Exchange in Leaves."